



SP Amplifier 8 IP

SP-AP008

This manual contains important information.
Please read before operating fixture.

Guangzhou Leahua Lighting Technology Ltd
[http:// www.leahualighting.com](http://www.leahualighting.com)

Index

1. Technical Specifications	2
2. Operation Instruction	3
3. Connecting diagram	5
4. Maintenance & Cleaning	6
4.1 Cleaning	6

Accessories

		Remark
CA8602A	1piece	
Manual	1piece	
Waterproof male	6piece	
Waterproof female	1piece	
Tail Plug	1piece	
Installed accessories	2piece	

1. Technical Specifications

Input Voltage:90-240V、 50-60Hz

Power Consumption: 6W

Digital signal:DMX512

Level: IP67

Weight: 1.62KG

Dimensions:

2. Operation Instruction

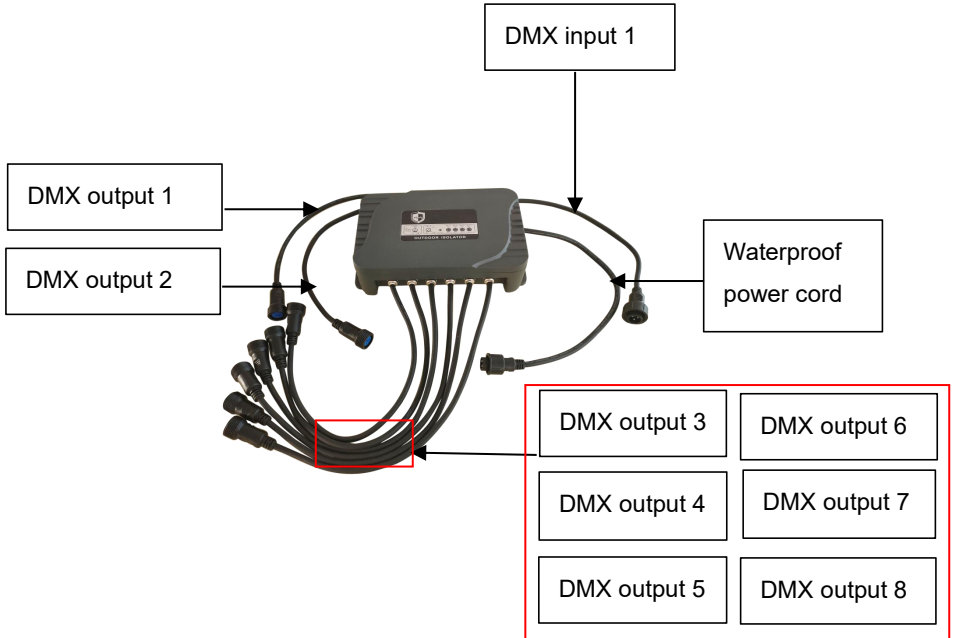

DMX512 Input: Connect to DMX512 console output

DMX512 Output: Connect to DMX512 lighting

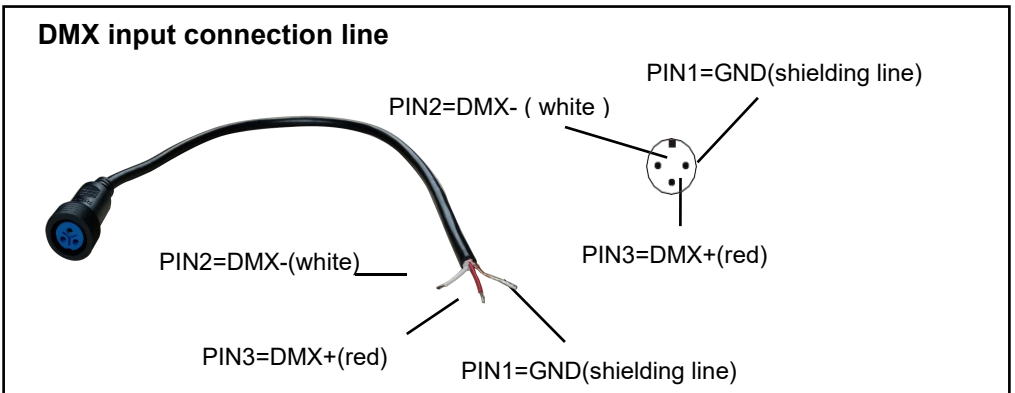

DMX output connection line

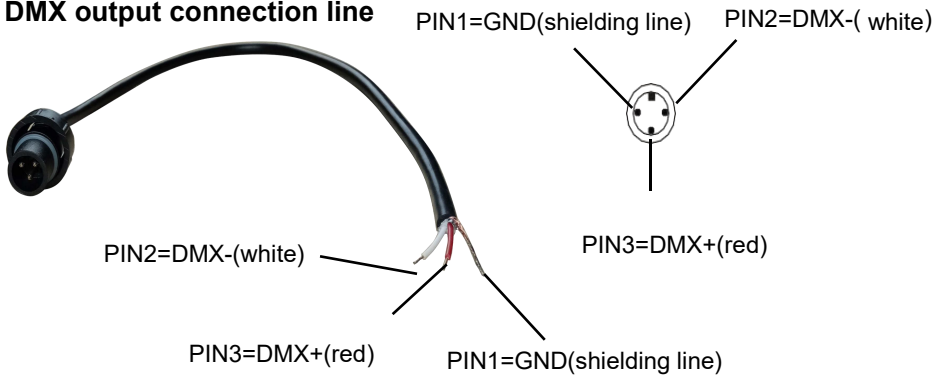

Power line connecting

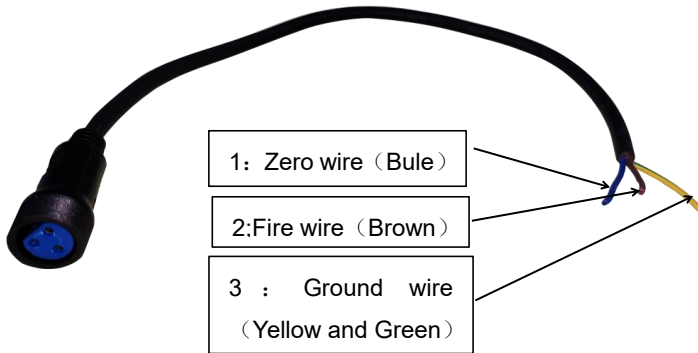

3. Connecting diagram



DMX512 controller

DMX512 amplifier

DMX512 light

DMX512 Signal connecting line need to use 128Net shielded wire,When the number of receivers for each output of the amplifier exceeds 48, need to add amplifier

Warning: When external power is connected, the neutral wire and ground wire of the live wire must not be connected wrongly, otherwise the amplifier will be burned

4. Maintenance & Cleaning

Regular maintenance is essential to ensure optimal performance and extend the service life of the fixture.

4.1 Cleaning

Disconnect the unit from power before any cleaning work.

Use a soft, lint-free cloth slightly dampened with mild detergent to clean the exterior surfaces.

Gently remove dust from ventilation slots, optical lenses, and cooling components using compressed air or a soft brush.

Avoid using solvents, alcohol, or abrasive materials that may damage the housing or optical elements.



Guangzhou Leahua Lighting Technology Ltd

Rm 1004, Building A
Baiyun Lake Future Technology Center
No,1 Xinghu Street, Shimen, Baiyun district
Guangzhou 510440, China
