



## **Crusier 470 BWS**

### **LH-C473**

This manual contains important information.  
Please read before operating fixture.

Guangzhou Leahua Lighting Technology Ltd  
[http:// www.leahualighting.com](http://www.leahualighting.com)

# Index

1. Safety Instructions .....	2
2. Appearance .....	3
3. Technical Specifications .....	4
4. Operation .....	9
4.1 Front panel operation: .....	9
4.2 Board instruction: .....	9
4.3 DMX address setting .....	11
5. DMX Protocol .....	13
6. Installation .....	23
6.1 Mounting & Rigging .....	23
6.2 Power connection .....	24
6.3 DMX Control Connection .....	24
6.4 Alignment/ Installation/Replacement of a lamp .....	25
7. Maintenance & Cleaning .....	27
7.1 Cleaning .....	27
7.2 Lubrication .....	27
7.3 Troubleshooting .....	27

## Accessories

Name	Quantity	Remark
User manual	1pc	
Folding clamp	1set	
Power cable	1pc	
DMX signal cable	1pc	
Safety cord	1pc	Optional

# 1. Safety Instructions

**WARNING!!! To reduce the risk of fire, electric shock, or injury to persons, follow these important safety instructions:**

- Check before use

Before operation, inspect the fixture for transportation damage. Do not use it if damaged. Unauthorized modification or improper use is not covered by warranty.

- Environment

The fixture is IP65-rated, suitable for indoor/outdoor use, and can operate in humid or dusty areas. Keep it away from excessive heat, fire, vibration, electrical surges, and strong light.

- Personnel & operation

Installation and operation must be performed by qualified personnel. Ensure all covers are securely in place, wear protective gear, and do not open the housing or attempt self-maintenance.

- Optical safety

Do not look directly into the light source. Do not use with dimmer packs. Maintain a minimum distance of 20 m from illuminated surfaces, and replace damaged optical components immediately.

- Electrical safety

Ensure correct voltage, proper grounding, and compliant power cords. Do not use damaged cables, and unplug by holding the plug. Avoid operating under heavy rain or extreme humidity, and avoid frequent on/off switching.

- Installation

Use the safety cord through the provided safety holes. Keep at least 50 cm ventilation clearance and do not mount on flammable surfaces or aim the beam at combustible objects (minimum 20 m).

- Temperature & normal conditions

Housing temperature may reach 45 – 75° C during operation. Slight smoke or odor may occur at first ignition and is considered normal.

## 2. Appearance

Front side & back side

Front panel & rear panel

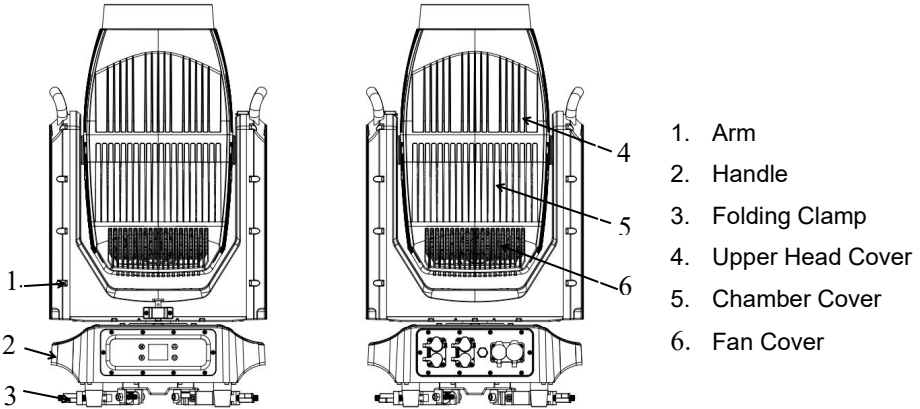

1. Arm
2. Handle
3. Folding Clamp
4. Upper Head Cover
5. Chamber Cover
6. Fan Cover

Front Panel of the Base

1. Menu Key
2. Return Key
3. Up Key
4. Down Key

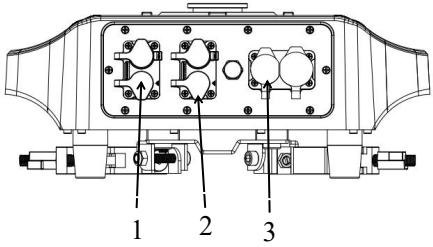
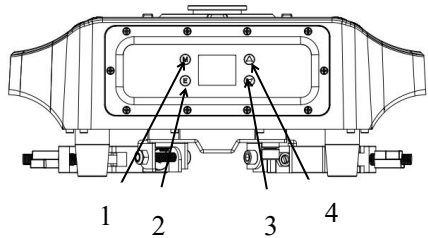

Rear Panel of the Base

1. Waterproof DMX3-pin in/out
2. Waterproof DMX5-pin in/out
3. Waterproof power socket

### 3. Technical Specifications

#### Power

Input Voltage Range: AC100-240V 50/ 60Hz

Power Consumption: 620W

#### Light Source

Light Source: 420W USHIO lamp

Color Temperature Output of Fixture: 6600K

Life Expectancy: 2500 hours( factory rated)

#### Zoom Range

Zoom Range: 2°-44°

#### Control

Display: LCD display

Control Mode: DMX512, master-slave, auto, sound, RDM







Control Channel: 34/ 39CH

#### Head Movement

Pan/ Tilt: 540°/ 270° with auto-correction

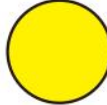
#### Colors

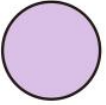
Color Wheel: 13 colors( including 2 CTO filters)+open

Dark Red	Dark Blue	Yellow	Light Green	Rose	Light Purple	Magenta
						
Dark Green	CTO 2700K	Blue	Orange	CTO 3200K	Sapphire	

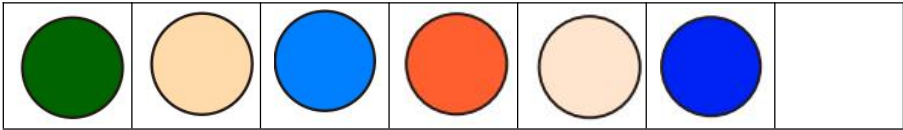

CMY: Linear CMY color mixing



**Static gobo wheel**

Static gobo wheel :14gobos+ open









Gobo1	Gobo2	Gobo3	Gobo4	Gobo5	Gobo6	Gobo7
Gobo8	Gobo9	Gobo10	Gobo11	Gobo12	Gobo13	Gobo14

**Rotating gobo wheel**

Rotating gobo wheel : 9gobos+ open

Outside diameter:16mm

Image diatmeter: 12mm





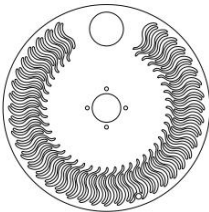

Gobo1	Gobo2	Gobo3	Gobo4	Gobo5	Gobo6	Gobo7
						
Gobo8	Gobo9					
						

Effect Wheel: 1 dynamic effect wheel





**Prism**

2×6-facet linear prism, 1×18-facet double-layer circular prism, 2×8-facet circular prism( different angle), 1×4-facet circular prism

Prism1	Prism2	Prism3	Prism4	Prism5	Prism6
					

**Frost**

Frost: 2 frost filter, light+medium

Frost1	Frost2
	

**Other Function**

Dimming: 0-100% linear dimming system

Strobe: 1-20 F.P.S, speed adjustable

Focus: Electronic focus function

Cooling System: Low noise and efficient fan cooling system

### **Connection**

Power Connection: Powercon in/ out

Signal Connection: DMX 3-pin + 5-pin in/ out

### **Housing**

Housing: Magnesium alloy body

Working Environment: -10°C-45°C

Protection Rate: IP65

### **Product dimensions**

Product Dimensions 394.4×310×751mm

### **Net weight**

30kg

### **Dimensions:**

Cruiser 470 BSW

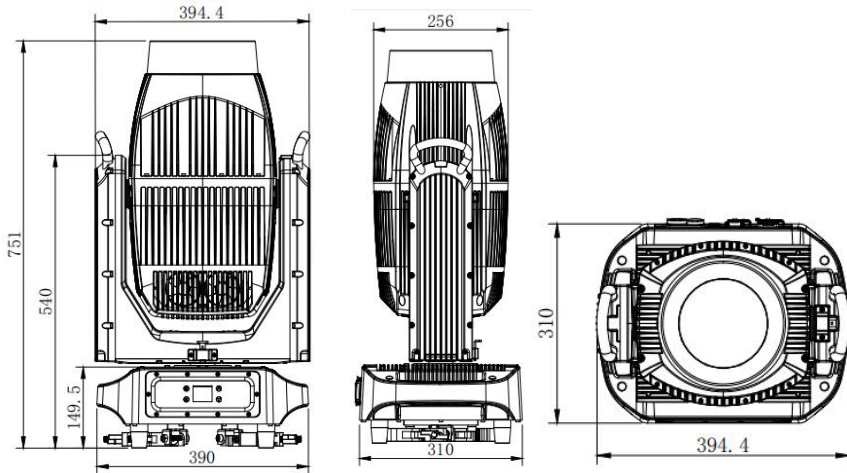

**Light output:**

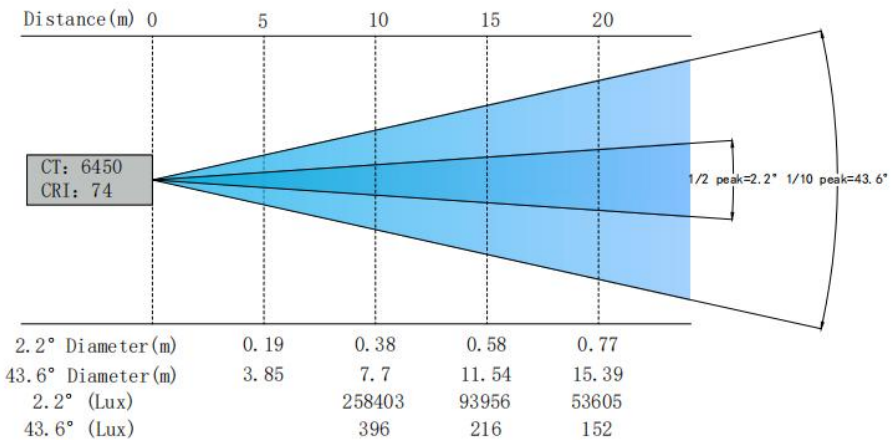

## 4. Operation

### 4.1 Front panel operation:

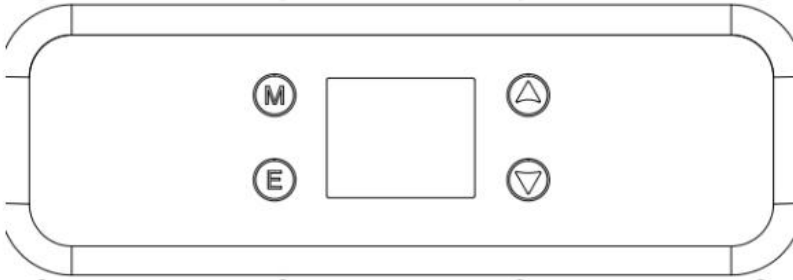

MENU	To enter into move backward or leave the menu
UP	To go backward to move up in the menu
DOWN	To go forward to move down in the menu
ENTER	To perform the desired functions

Pressing any button from the home screen will show the selectable menu items from the menu map. When a menu function is selected, the display will immediately show the first available option for the selected menu function. To select a menu item, press <ENTER>.

Use the <UP> and <DOWN> buttons to navigate the menu options. Press the <ENTER> button to select the menu function currently displayed, or to enable a menu option. To return to the previous option or menu without changing the value, press the <MENU> button.

### 4.2 Board instruction:

DMX Address	001-512	
Channel Mode	34/39	
Reset	Moter power	on/off
	Pan Tilt	

	Color		
	Gobo		
	Beam path		
Run	DMX/User/Auto		
Lamp	On/Off		
Channel	Lock Manual Ctr	No/yes	
	Pan	000-255	
	Tilt	000-255	
	P/T speed	000-255	
	C	000-255	
	M	000-255	
	Y	000-255	
	Color	000-255	
	Gobo	000-255	
	Effect	000-255	
	Gobo wheel	000-255	
	Rot Gobo	000-255	
	Prism 1	000-255	
	Prism 1 Rot	000-255	
	Prism 2	000-255	
	Prism2 Rot	000-255	
	Frost	000-255	
	Zoom	000-255	
	Focus	000-255	
	Strobe	000-255	
Dim	000-255		
Option	M/S mode	Master/slave	
	Pan/Tilt	Manual Pan/Tilt	OFF/ON
		Invert Pan	OFF/ON
		Invert Tilt	OFF/ON
		Speed Chn RT	OFF/ON
	User Program	Manual	
Record			

		Clear all	
	Auto master	Yes/no	
	If no DMX	Power on	Middle/No effect/User/Auto
		Run time	Clear/Keep
Advanced	Adj		
	Display	Auto Lock	on/off
		Sleep	30 Sec/2min/10min
		Flip	On/off
	Language	Chinese/English	
	Factory Setting		
	Adj recover		
Information	DMX monitor	Channel1-29	0-255
	System errors		
	Lamp	Lamp hours	
		Reset Lamp Hours	
	product code		

### 4.3 DMX address setting

Each fixture must be assigned a unique DMX start address within the 001 – 512 range. The start address represents the first channel the fixture occupies. This product provides two DMX modes (34/ 39CHchannels); therefore, the next fixture's start address must be calculated according to the number of channels used in the selected mode to avoid overlapping addresses.

For example, when operating in 34channel mode, set Fixture 1 to 001, Fixture 2 to 035, Fixture 3 to 069, Fixture 4 to 103, etc.

DMX Mode	Fixture1	Fixture2	Fixture3	Fixture4	...
34CH	001	35	69	103	...
39CH	001	40	79	118	...

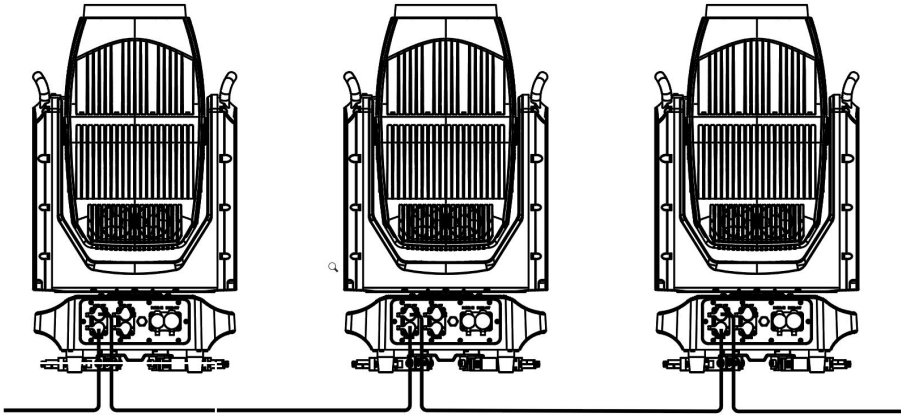

DMX Input

DMX Output

## 5. DMX Protocol

Mode/channel					DMX value	Function
49CH	42CH	50CH	43CH	51CH		
1	1	1	1	1		<b>Pan</b>
					0-255	0-540 degrees
2	2	2	2	2		<b>Pan fine</b>
					0-255	0-2 degrees
3	3	3	3	3		<b>Tilt</b>
					0-255	0-265 degrees
4	4	4	4	4		<b>Tilt fine</b>
					0-255	0-1 degree
5	5	5	5	5		<b>Pan/ Tilt speed, Pan/ Tilt time</b>
					0	Standard Mode
					1	Maximum speed
						<b>In speed mode</b>
					1-255	Speed from max. to min.
						<b>In time mode</b>
	1-255	Time from 0.1 seconds to 25.5 seconds				
6	6	6	6	6		<b>Function Channel 1</b>
					0-33	empty
					34-35	Dimming curve, cubic
					36-109	empty
					110-114	Dimming curve, square
					115-119	Dimming curve, linear
					120-139	empty
					140-149	P/T reset
					150-159	Color system reset
					160-169	Gobo wheel reset
					170-179	Stroboscopic reset (none for LED)

					180-189	Optical path system reset
					190-199	Effect wheel reset
					200-209	Reset all
					210-255	empty
						<b>Function Channel 2</b>
					0-4	empty
					5-9	Dimming frequency: 2K
					10-14	Dimming frequency: 4K
					15-19	Dimming frequency: 15K
					20-24	Dimming frequency: 25K
					25-255	empty
8	8	8	8	8		empty
9	9	9	9	9		empty
						<b>Color wheel 1</b>
					0-124	Continual positioning
					125-129	white
					130-141	Color 1
					142-152	Color 2
					153-165	Color 3
					166-177	Color 4
					178-189	Color 5
					190-215	Forwards rainbow effect from fast to slow
					216-217	No rotation
					218-243	Backwards rainbow effect from slow to fast
					244-249	Reserved
					250-255	Random colors, from fast to slow
						<b>Color wheel 1 fine</b>
11	*	11	*	11	0-255	Fine positioning
						<b>Color wheel 2</b>
12	11	12	11	12	0-124	Continual positioning

					125-129	white
					130-141	Color 1
					142-153	Color 2
					154-165	Color 3
					166-177	Color 4
					178-189	Color 5
					190-215	Forwards rainbow effect from fast to slow
					216-218	No rotation
					219-243	Backwards rainbow effect from slow to fast
					244-249	Reserved
					250-255	Random colors, from fast to slow
13	*	13	*	13		<b>Color wheel 2 fine</b>
					0-255	Fine positioning
14	12	14	12	14		<b>Cyan</b>
					0-255	Cyan from min. saturation to full cyan
15	13	15	13	15		<b>Magenta</b>
					0-255	Magenta from min. saturation to full magenta
16	14	16	14	16		<b>Yellow</b>
					0-255	Yellow from min. saturation to full yellow
17	15	17	15	17		<b>CTO</b>
					0-255	The color saturation ranges from low to high
*	*	18	16	18		empty
18	16	19	17	19		empty
19	17	20	18	20		empty
20	18	21	19	21		<b>CMY+CTO+ Color wheel time</b>

					0-255	Time of CMY, CTO and Colour wheels movement from 0.1 seconds to 25.5 seconds
21	19	22	20	22		empty
22	20	23	21	23		<b>Effect wheel</b>
					0-50	empty
					51-255	Effect wheel cut in
23	21	24	22	24		<b>Effect wheel rotation</b>
					0	No rotation
					1-127	Forwards rotation from fast to slow
					128	No rotation
					129-255	Backwards rotation from slow to fast
24	22	25	23	25		<b>Animation effect</b>
					0-7	no
					8-9	Animation effect 1
					10-11	Animation effect 2
					12-13	Animation Effect 3
					14-15	Animation effect 4
					16-17	Animation effect 5
					18-19	Animation effect 6
					20-21	Animation Effect 7
					22-23	Animation Effect 8
					24-25	Animation Effect 9
					26-27	Animation Effect 10
					28-255	Random effect
25	23	26	24	26		<b>Fixed gobo wheel</b>
					0-8	Open/Hole
					9-17	Gobo 1
					18-26	Gobo 2
					27-35	Gobo 3

					36-44	Gobo 4
					45-53	Gobo 5
					54-62	Gobo 6
					63-71	Gobo 7
					72-80	Gobo 8
					81-91	Gobo 9
						<b><u>Shaking gobos from slow to fast</u></b>
					92-103	Gobo 1
					104-115	Gobo 2
					116-127	Gobo 3
					128-139	Gobo 4
					140-151	Gobo 5
					152-163	Gobo 6
					164-175	Gobo 7
					176-187	Gobo 8
					188-199	Gobo 9
					200-201	Open/Hole
					202-222	Forwards gobo wheel rotation from fast to slow
					223-243	Backwards gobo wheel rotation from slow to fast
					244-249	Reserved
					250-255	Auto random gobo selection, from fast to slow
						<b>Rotating gobo wheel</b>
						<i>Index- set indexing on channel 27/25/26/28/29</i>
26	24	27	25	27	0-3	Open/Hole
					4-7	Gobo 1
					8-11	Gobo 2
					12-15	Gobo 3
					16-19	Gobo 4

				20-23	Gobo 5
				24-27	Gobo 6
				28-31	Gobo 7
					<i>Rotation- set rotation on channel 27/25/26/28/29</i>
				32-35	Gobo 1
				36-39	Gobo 2
				40-43	Gobo 3
				44-47	Gobo 4
				48-51	Gobo 5
				52-55	Gobo 6
				56-59	Gobo 7
					<b><u>Continual positioning</u></b>
					<i>Index- set indexing on channel 27/25/26/28/29</i>
				60	Open/Hole
				68	Gobo 1
				76	Gobo 2
				84	Gobo 3
				92	Gobo 4
				101	Gobo 5
				109	Gobo 6
				117	Gobo 7
				125	Open/Hole
					<b><u>Continual positioning</u></b>
					<i>Rotation- set rotation on channel 27/25/28/26/29</i>
				125	Open/Hole
				133	Gobo 1
				141	Gobo 2
				149	Gobo 3
				157	Gobo 4
				166	Gobo 5

					174	Gobo 6
					182	Gobo 7
					189-201	Open/Hole
					202-222	Forwards gobo wheel rotation from fast to slow
					223-243	Backwards gobo wheel rotation from slow to fast
					244-249	Reserved
					250-255	Auto random gobo selection from fast to slow
*	*	*	*	28		<b>Rotating gobo wheel- fine positioning</b>
					0-255	Fine positioning
27	25	28	26	29		<b>Rotation gobo indexing and rotation</b>
					0	No rotation
					1-127	Forwards gobo rotation from fast to slow
					128	No rotation
					129-255	Backwards gobo rotation from slow to fast
28	*	29	*	30		<b>Rotation gobo indexing and rotation- fine</b>
					0-255	Fine indexing/ rotation
29	26	30	27	31		<b>Prism</b>
					0-19	Open position- hole
					20-73	Prism indexing
					74-255	Prism rotation
30	27	31	28	32		<b>Prism indexing/ rotation</b>
					0-255	Prism Index
						<b><u>Prism rotation</u></b>
					0	No rotation
					1-127	Forwards prism rotation from

						fast to slow
					128	No rotation
					129-255	Backwards prism rotation from slow to fast
31	28	32	29	33		<b>Frost</b>
					0	empty
					1-127	Light frost
					128-255	Medium frost
32	29	33	30	34		<b>Iris</b>
					0	Open
					1-179	From max. diameter to min. diameter
					180-191	Open
					192-219	Pulse opening from slow to fast
					220-247	Pulse closing from fast to slow
248-255	Random pulse opening and closing					
33	*	34	*	35		<b>Iris-fine</b>
					0-255	Fine iris movement
34	30	35	31	36		<b>Zoom</b>
					0-255	Zoom: The beam Angle increases from small to large
35	*	36	*	37		<b>Zoom- fine</b>
					0-255	Fine zooming
36	31	37	32	38		<b>Focus</b>
					0-255	Continuously adjustment from far to near
37	*	38	*	39		<b>Focus- fine</b>
					0-255	Fine focusing
38	32	39	33	40		<b>Framing shutters module rotation</b>

					0-255	Rotation
39	33	40	34	41		<b>Framing shutter 1- movement</b>
					0	empty
					1-255	Movement from Outward to Inward
40	34	41	35	42		<b>Framing shutter 1- swivelling</b>
					0	empty
					1-255	Swivelling from -30 degrees towards +30 degrees
41	35	42	36	43		<b>Framing shutter 2- movement</b>
					0	empty
					1-255	Movement from Outward to Inward
42	36	43	37	44		<b>Framing shutter 2- swivelling</b>
					0	empty
					1-255	Swivelling from -30 degrees towards +30 degrees
43	37	44	38	45		<b>Framing shutter 3- movement</b>
					0	empty
					1-255	Movement from Outward to Inward
44	38	45	39	46		<b>Framing shutter 3- swivelling</b>
					0	empty
					1-255	Swivelling from -30 degrees towards +30 degrees
45	39	46	40	47		<b>Framing shutter 4- movement</b>

					0	empty
					1-255	Movement from Outward to Inward
46	40	47	41	48		<b>Framing shutter 4-swivelling</b>
					0	empty
					1-255	Swivelling from -30 degrees towards +30 degrees
47	41	48	42	49		<b>Shutter/strobe</b>
					0-31	Close
					32-63	Open
					64-95	Shutter effect, from slow to fast
					96-127	Open
					128-143	Opening pulse in sequences from slow to fast
					144-159	Closing pulse in sequences from fast to slow
					160-191	Open
					192-223	Random strobe-effect, from slow to fast
					224-255	Open
48	42	49	43	50		<b>Dimming intensity</b>
					0-255	Dimmer intensity: from 0% to 100%
49	*	50	*	51		<b>Dimming intensity- fine</b>
					0-255	Fine dimming

## 6. Installation

### 6.1 Mounting & Rigging

- Prepare the fixture

Ensure the fixture is in good condition and the ventilation openings are unobstructed.

- Mount using the built-in folding clamp

Hang the fixture directly onto the truss or mounting structure using the integrated folding clamp.

Always lift or carry the fixture using the handles—not the clamp.

- Install the safety cable

Pass the safety cable through the two safety-cable holes on the base and secure it to an independent safety point.

The safety cable must be rated to withstand 10× the fixture's weight.

- Lock / Unlock Pan & Tilt

Lock Pan and Tilt before moving the fixture; unlock them before powering on.

Do not operate the fixture while Pan/Tilt is locked.

- Final Safety Check

Confirm the hook is fully engaged, the safety cable is properly secured, and the mounting structure can safely support the fixture's weight.

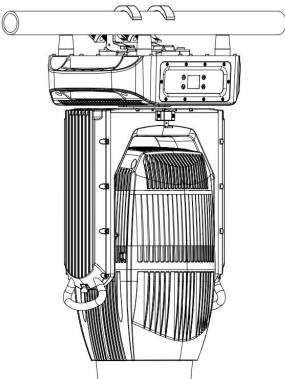

## 6.2 Power connection

Please checking the power equipment supported.

Please put the plug of power source wire connect with the main power source .

( EU )Wire	Wire(America)	Direction of wire	General marks
Brown	Black	Live	L
Light blue	White	Neutral	N
Yellow/Green	Green	Earth	

## 6.3 DMX Control Connection

This fixture supports DMX512 (1990) control protocol and is equipped with both 5-pin and 3-pin XLR connectors for data input and output. Use a twin-screened DMX cable with conductors of at least 0.5 mm<sup>2</sup> , ensuring correct wiring for the selected connector type.

Connect the controller’s DMX OUT to the first fixture’s DMX IN, then link fixtures DMX OUT → DMX IN in a daisy-chain. For optimal signal integrity, install a **DMX terminator** on the DMX OUT of the final fixture.

Ensure no pin makes contact with the connector housing or other pins. Before use, test cables with an ohm meter to verify correct polarity and to ensure no pins or shield are shorted to ground, as this may result in data errors or unstable operation.

For convenience, connect fixtures in the physical order they are installed, rather than by DMX address sequence.

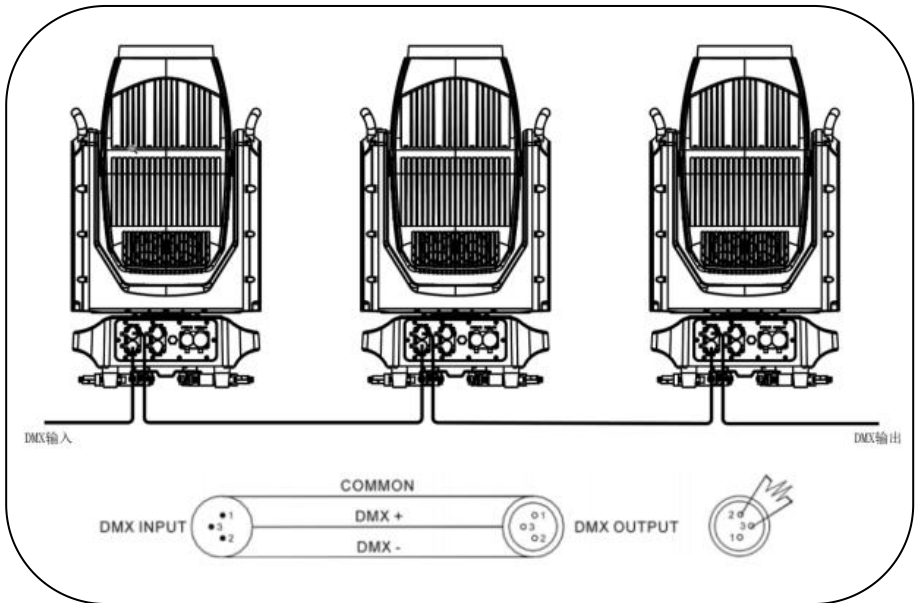

## 6.4 Alignment/ Installation/Replacement of a lamp

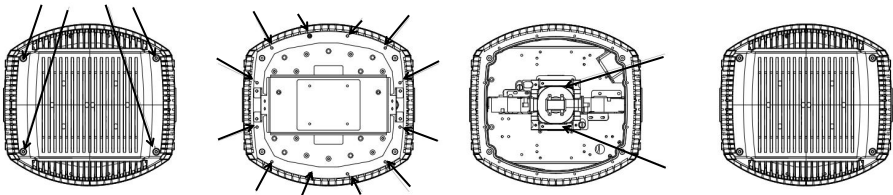

**Figure 1:** First loosen the 4 screws of the head fan cover and remove the cover.

**Figure 2:** Then loosen the 12 screws of the radiator module, unplug the fan wire, and remove the module.

**Figure 3:** Unplug the bulb power cord, loosen the 4 screws of the bulb pressure plate, then take out the bulb for replacement.

**Figure 4:** After replacing the bulb, first ensure the bulb is clamped tightly before plugging in the bulb power cord, then turn on the light and adjust the bulb's center point to the middle position. After adjustment, install the radiator module, plug in the fan wire, and finally attach the fan cover.

### Operational Safety Precautions

1. Power-off Operation: The main power supply of the equipment must be cut off before operation to avoid the risk of electric shock.
2. Anti-scalding Treatment: If the equipment has just been used, wait for the lamp body and bulb to cool down before operation to prevent scalding from high temperatures.
3. Handle with Care: The bulb is a fragile item; avoid collision and extrusion when taking and placing it. When disassembling and assembling the radiator module, operate steadily to prevent damage to parts.
4. Wiring Specification: Align the connectors when plugging in the wires; avoid forced plugging and unplugging, which may cause poor contact or damage to the circuit.

## **7. Maintenance & Cleaning**

Regular maintenance is essential to ensure optimal performance and extend the service life of the fixture.

### **7.1 Cleaning**

Disconnect the unit from power before any cleaning work.

Use a soft, lint-free cloth slightly dampened with mild detergent to clean the exterior surfaces.

Gently remove dust from ventilation slots, optical lenses, and cooling components using compressed air or a soft brush.

Avoid using solvents, alcohol, or abrasive materials that may damage the housing or optical elements.

### **7.2 Lubrication**

This fixture is designed with sealed or maintenance-free moving parts. Under normal operating conditions, no additional lubrication is required.

If abnormal noise or movement resistance is observed, contact qualified service personnel before applying any lubricant.

### **7.3 Troubleshooting**

If the fixture does not power on, verify the power supply, cables, and connectors.

For control issues, check DMX addressing, cable integrity, and ensure proper 3-pin/5-pin XLR connections.

Overheating or unexpected shutdown may indicate blocked ventilation; inspect and clean air inlets and outlets.

If problems persist after basic checks, discontinue use and contact authorized service technicians.



**LEAHUA**

Guangzhou Leahua Lighting Technology Ltd

---

---

Rm 1004, Building A  
Baiyun Lake Future Technology Center  
No.1 Xinghu Street, Shimen, Baiyun district  
Guangzhou 510440, China

---

---