



## **Crusier LED 300 BWS**

**LH -C330**

This manual contains important information.  
Please read before operating fixture.

Guangzhou Leahua Lighting Technology Ltd  
[http:// www.leahualighting.com](http://www.leahualighting.com)

# Index

1. Safety Instructions .....	2
2. Appearance .....	3
3. Technical Specifications .....	4
4. Operation .....	10
4.1 Front panel operation: .....	10
4.2 Board instruction: .....	10
4.3 DMX address setting: .....	12
5. DMX Protocol .....	14
6. Installation .....	18
6.1 Mounting & Rigging .....	18
6.2 Power connection .....	19
6.3 DMX Control Connection .....	19
6.4 Alignment/ Installation/Replacement of a lamp .....	20
7. Maintenance & Cleaning .....	22
7.1 Cleaning .....	22
7.2 Lubrication .....	22
7.3 Troubleshooting .....	22

## Accessories

Name	Quantity	Remark
User manual	1pc	
Folding clamp	1set	
Power cable	1pc	
DMX signal cable	1pc	
Safety cord	1pc	Optional

# 1. Safety Instructions

**WARNING!!! To reduce the risk of fire, electric shock, or injury to persons, follow these important safety instructions:**

- Check before use

Before operation, inspect the fixture for transportation damage. Do not use it if damaged. Unauthorized modification or improper use is not covered by warranty.

- Environment

The fixture is IP65-rated, suitable for indoor/outdoor use, and can operate in humid or dusty areas. Keep it away from excessive heat, fire, vibration, electrical surges, and strong light.

- Personnel & operation

Installation and operation must be performed by qualified personnel. Ensure all covers are securely in place, wear protective gear, and do not open the housing or attempt self-maintenance.

- Optical safety

Do not look directly into the light source. Do not use with dimmer packs. Maintain a minimum distance of 20 m from illuminated surfaces, and replace damaged optical components immediately.

- Electrical safety

Ensure correct voltage, proper grounding, and compliant power cords. Do not use damaged cables, and unplug by holding the plug. Avoid operating under heavy rain or extreme humidity, and avoid frequent on/off switching.

- Installation

Use the safety cord through the provided safety holes. Keep at least 50 cm ventilation clearance and do not mount on flammable surfaces or aim the beam at combustible objects (minimum 20 m).

- Temperature & normal conditions

Housing temperature may reach 45 – 75° C during operation. Slight smoke or odor may occur at first ignition and is considered normal.

## 2. Appearance

Front side & back side

Front panel & rear panel

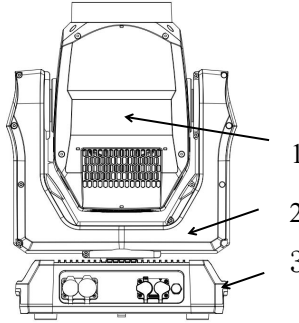
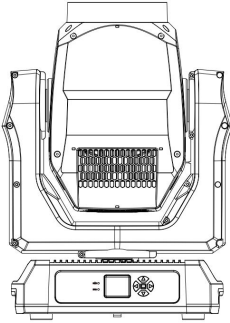

1. Face Cover
2. Arm
3. Handle

Front Panel of the Base

1. Left Key
2. Enter Key
3. Down Key
4. Right Key
5. Up Key

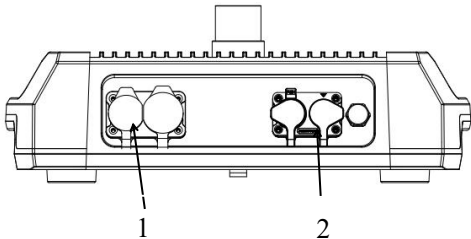
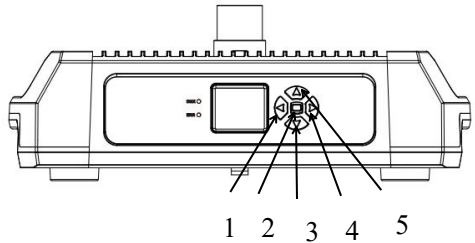

Rear Panel of the Base

1. Waterproof DMX3-pin in/out
2. Waterproof power socket

### 3. Technical Specifications

#### Power

Input Voltage: AC100-240V 50/ 60Hz

Power Consumption: 380W

#### Light source

Light Source 300W white LED module

CCT: 9100K

CRI> 70

Life expectancy: About 20000hours( factory rated)

#### Zoom range

Zoom range: 2°-40°

#### Control













Display: LCD display

Control mode: DMX512, master-slave, auto, sound, RDM

Channel: 26CH

#### Colors

Color wheel: 13 colors( including 2CTO filters)+open

Dark -red	Navy -blue	Yellow	Light -green	Magenta	Lavender	Pink
						
Dark -green	CTO -2700K	Blue	Orange	CTO -3200K	UV-Congo blue	
						

CMY: Linear CMY color mixing

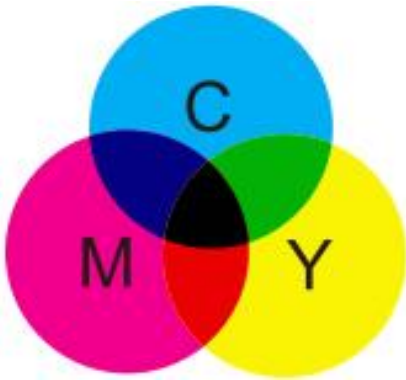

Variable CTO: 3200-9100K linearly adjustable



### Static gobo wheel

Static gobo wheel : 11gobos+ open









Gobo1	Gobo1	Gobo1	Gobo1	Gobo1	Gobo1
Gobo1	Gobo1	Gobo1	Gobo1	Gobo1	Gobo1

### Rotating gobo wheel

Rotating gobo wheel : 9gobos+ open

Outside diameter:11.8mm

Image diatmeter: 9.5mm



Gobo1	Gobo1	Gobo1	Gobo1	Gobo1
				
Gobo1	Gobo1	Gobo1	Gobo1	
				

**Prism/Frost**

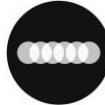
Prism: 1×6-facet linear prism, 1×3-facet circular prism

Gobo1	Gobo2
	

Frost: 2 frost filter

Gobo1	Gobo2
	

**Dimming/Strobe**

Dimming: 0-100% linear dimming system

Strobe: 0-20 F.P.S, speed adjustable

**Other Function**

Focus: Electronic focus function

Cooling System: Low noise and efficient fan cooling system

## **Head movement**

Pan 540°, Tilt 270° with auto-correction

## **Housing**

Housing: Die-casting aluminum, nylon and glass fiber

Protection rate: IP65

## **Working temperature**

Working temperature: -10°C-45°C

Connection

Power connection: Powercon in/out

DMX connection: DMX 3-pin in / out

## **Product dimensions**

388×256×534mm

## **Net weight**

18.5kg

## **Dimensions:**

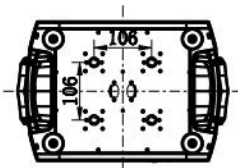
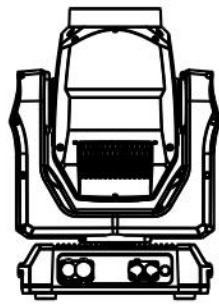
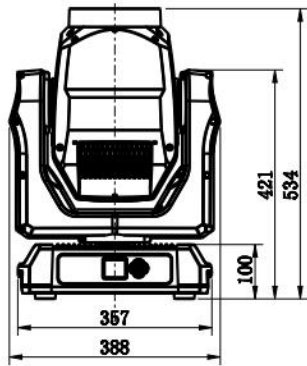

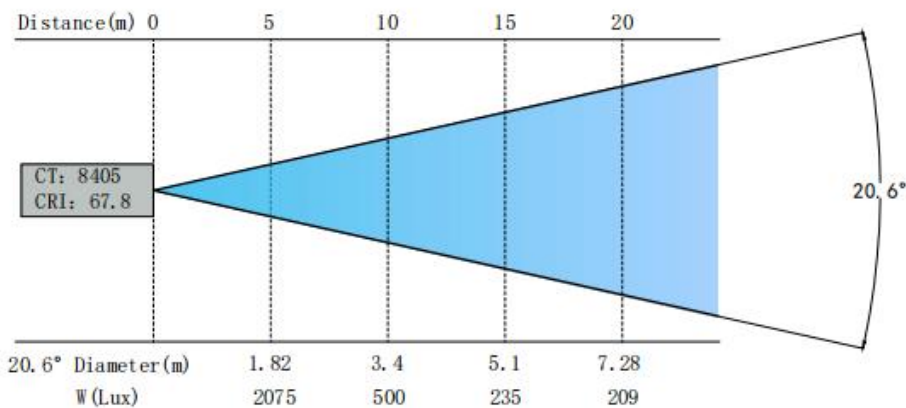
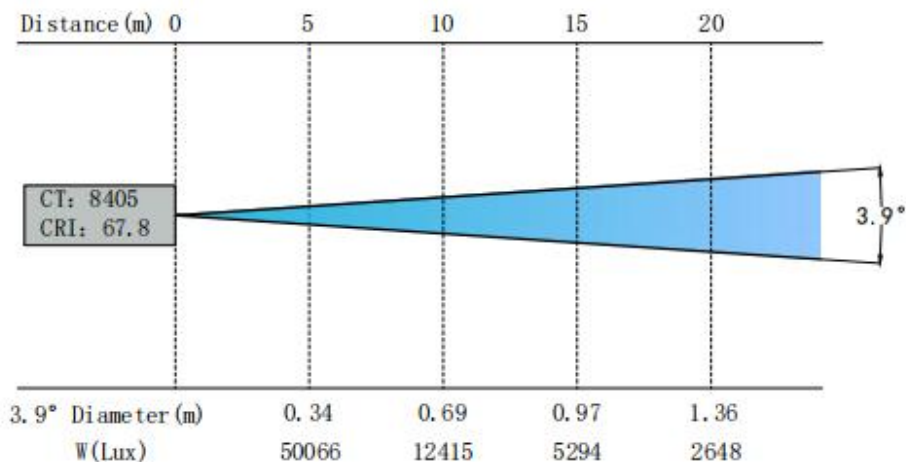
**Light output:**

# 4. Operation

## 4.1 Front panel operation:

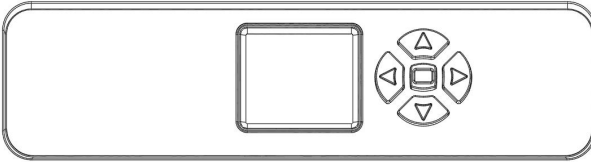

Enter



UP / DOWN

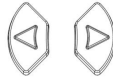

Left Key / Right Key

Enter	To enter into move backward or leave the menu
UP	To go backward to move up in the menu
DOWN	To go forward to move down in the menu
Left	To go backward to previous level
Right	To go forward to next level

Pressing any button from the home screen will show the selectable menu items from the menu map. When a menu function is selected, the display will immediately show the first available option for the selected menu function. To select a menu item, press <ENTER>.

Use the <UP> <DOWN> <Left> <Right> buttons to navigate the menu options. Press the <ENTER> button to select the menu function currently displayed, or to enable a menu option.

## 4.2 Board instruction:

ADDR	Ch	001-512
	Next	Next device
	Prev	Previous device

MODE	Mode Select	DMX
		Auto
	M/S Mode	Auto/Master/Slave
	Dimer Mode	Mode/Mode2/Mode3/Off
	Fan Mode	Auto/High/Low
DISP	语言	English/中文
	Screen_Rot	Auto/Close/Open
	Screen_Saver	On/Off
	DMX_Indicate	Mode1-2
	Screen_Light	01-10
SCENE	1. Pan	000-255
	2. Pan fine	000-255
	3. Tilt	000-255
	4. Tilt fine	000-255
	5. X/Y speed	000-255
	6. Dimmer	000-255
	7. Strobe	000-255
	8. R1	000-255
	9. G1	000-255
	10. B1	000-255
	11. W1	000-255
	12. R2	000-255
	13. G2	000-255
	14. B2	000-255
	15. W2	000-255
	16. R3	000-255
	17. G3	000-255
	18. B3	000-255
	19. W3	000-255
	20. Zoom	000-255
	21. LED.EF	000-255
	22. LED.SP	000-255
	23. Effect	000-255

	24. Effect.spd	000-255
	25. Eff.Dimmer	000-255
	26. Reset	000-255
SETUP	Channel	18/26CH
	Pan Invert	On/Off
	Tilt Invert	On/Off
	P/T Rectify	On/Off
	Data Hold	On/off
	Channel	26CH
	Reset	On/Off
	Factor Set	On/Off
	Exit	
Infor	Total Time	
	Light_time	xxxx: xx
	Error_logging	
	Version	AT.3.0
	Fixture_Status	
	Stepper inf	

### 4.3 DMX address setting:

Each fixture must be assigned a unique DMX start address within the 001 - 512 range. The start address represents the first channel the fixture occupies. This product provides one DMX modes 26channels; therefore, the next fixture's start address must be calculated according to the number of channels used in the selected mode to avoid overlapping addresses. For example, when operating in 26-channel mode, set Fixture 1 to 001, Fixture 2 to 27, Fixture 3 to 53, Fixture 4 to 79, etc.

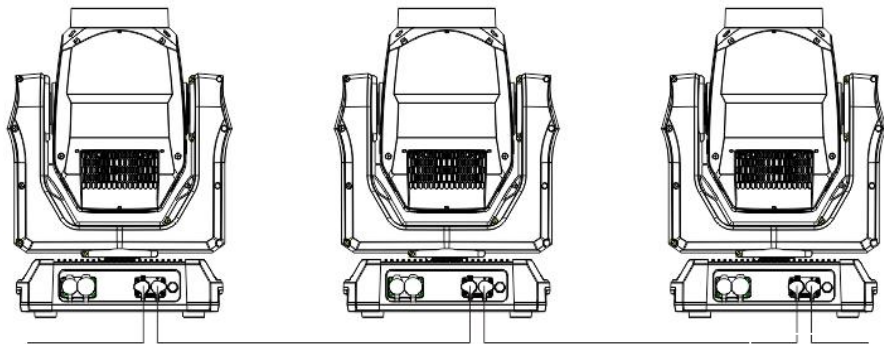

Dmx Input

Dmx Output

# 5. DMX Protocol

26CH	Function	DMX value	Description
1	Pan	0-255	Pan movement 0-540°
2	Pan fine	0-255	Pan fine movement 0-2°
3	Tile	0-255	Tilt movement 0-270°
4	Tile fine	0-255	Tilt fine movement 0-1°
5	Pan/ Tilt speed	0 - 255	From fast to slow
6	Reset	0-249	No function
		250-255	Reset after 3 seconds
7	Color wheel	0 - 129	Linear Color adjustment
		130-131	Open
		132-136	Color 1
		137-140	Color 2
		141-145	Color 3
		146-149	Color 4
		150-154	Color 5
		155-159	Color 6
		160-163	Color 7
		164-168	Color 8
		169-172	Color 9
		173-175	Color 10
		178-181	Color 11
		182-186	Color 12
		187-191	Color 13
		192-220	Forward rotation from fast to slow
221-255	Backward rotation from slow to fast		
8	Color wheel	000-255	Fine position

	fine		
9	Gobo	0-10	Open
		11-22	Gobo 1
		23-33	Gobo 2
		34-45	Gobo 3
		46-56	Gobo 4
		57-68	Gobo 5
		69-79	Gobo 6
		80-91	Gobo 7
		92-102	Gobo 8
		103-114	Gobo 9
		115-125	Gobo 10
		126-137	Gobo 11
		138-164	Forward rotation from fast to slow
		165-189	Backward flow from slow to fast
		190-195	Gobo 1 shaking
		196-201	Gobo 2 shaking
		202-207	Gobo 3 shaking
		208-213	Gobo 4 shaking
		214-219	Gobo 5 shaking
		220-224	Gobo 6 shaking
		225-230	Gobo 7 shaking
		231-236	Gobo 8 shaking
237-242	Gobo 9 shaking		
243-248	Gobo 10 shaking		
249-255	Gobo 11 shaking		
10	Gobo rotation	0-5	Open
		6-11	Gobo 1
		12-18	Gobo 2
		19-24	Gobo 3
		25-31	Gobo 4
		32-37	Gobo 5
		38-43	Gobo 6

		44-50	Gobo 7
		51-56	Gobo 8
		57-64	Gobo 9
		65-128	Forward rotation from fast to slow
		129-190	Backward rotation from fast to slow
		191-197	Gobo 1 shaking
		198-204	Gobo 2 shaking
		205-211	Gobo 3 shaking
		212-218	Gobo 4 shaking
		219-225	Gobo 5 shaking
		226-232	Gobo 6 shaking
		233-239	Gobo 7 shaking
		240-246	Gobo 8 shaking
		247-255	Gobo 9 shaking
11	Gobo rotation	0-127	Gobo rotation 0-360°
		128-191	Backward rotation from fast to slow
		192	Stop
		193-255	Forward rotation from slow to fast
12	Rotation fine	000-255	0-100%
13	Prism	0-63	Prism rotation 0-360°
		64-127	Prism 1 index
		128-191	Prism 2 index
		192-255	Prism 1 & Prism 2
14	Prism1 rotation	0-20	Prism 1 rotation 0-360°
		21-127	Backward rotation
		128-191	Backward rotation from fast to slow
		192-255	Forward rotation from slow to fast
15	Prism2 rotation	0-20	Prism 2 rotation 0-360°
		21-127	Backward rotation
		128-191	Backward rotation from fast to slow
		192-255	Forward rotation from slow to fast
16	Frost	0-127	NO

		128-163	Frost 1( light)
		164-255	Frost 2( medium)
17	Zoom	000-255	0-100%
18	Zoom fine	000-255	0-100%
19	Focus	000-255	0-100%
20	Focus fine	000-255	0-100%
21	C	000-255	0-100%
22	M	000-255	0-100%
23	Y	000-255	0-100%
24	CTO	000-255	0-100%
25	Shutter	0-8	Closed
		9-33	Shutter effect 1 from slow to fast
		34-56	Shutter effect 2 from slow to fast
		57-79	Shutter effect 3 from slow to fast
		80-145	Shutter effect 4 from slow to fast
		146-179	Pulse shutter effect from slow to fast
		180-239	Random shutter effect from slow to fast
		240-255	Open
26	Dimmer	0-255	0-100%

## 6. Installation

### 6.1 Mounting & Rigging

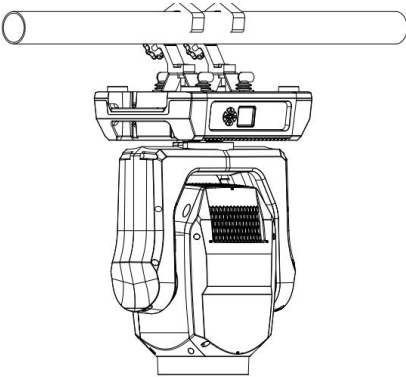

- **Attach Mounting Hardware**

Install the 2 × ¼-turn quick-lock Omega brackets to the base, then secure suitable rated C- or O-clamps to the brackets.

- **Position and Rig the Fixture**

Mount the fixture onto a stable truss or structure using clamps rated to hold at least 10× the fixture’s weight.

Always lift the fixture using the handles—not the clamps.

- **Install the Safety Cable**

Run the safety cable through the two safety-cable holes on the base and secure it to an independent safety point.

Ensure the safety cable is rated for 10× the fixture’s weight.

- **Ensure Ventilation**

Verify that fans and ventilation openings are unobstructed and that sufficient space is available around the fixture.

- **Lock / Unlock Pan & Tilt**

Lock Pan and Tilt before moving the fixture.

Unlock them before powering on.

Never operate the fixture while Pan/Tilt is locked.

- Final Stability Check

Ensure all clamps, screws, and safety cable connections are firmly secured, and confirm the mounting structure can support the fixture's weight.

## 6.2 Power connection

Please checking the power equipment supported.

Please put the plug of power source wire connect with the main power source .

( EU )Wire	Wire(America)	Direction of wire	General marks
Brown	Black	Live	L
Light blue	White	Neutral	N
Yellow/Green	Green	Earth	

## 6.3 DMX Control Connection

This fixture supports DMX512 (1990) control protocol and is equipped with and 3-pin XLR connectors for data input and output. Use a twin-screened DMX cable with conductors of at least 0.5 mm<sup>2</sup> , ensuring correct wiring for the selected connector type.

Connect the controller's DMX OUT to the first fixture's DMX IN, then link fixtures DMX OUT → DMX IN in a daisy-chain. For optimal signal integrity, install a **DMX terminator** on the DMX OUT of the final fixture.

Ensure no pin makes contact with the connector housing or other pins.

Before use, test cables with an ohm meter to verify correct polarity and to ensure no pins or shield are shorted to ground, as this may result in data errors or unstable operation.

For convenience, connect fixtures in the physical order they are installed, rather than by DMX address sequence.

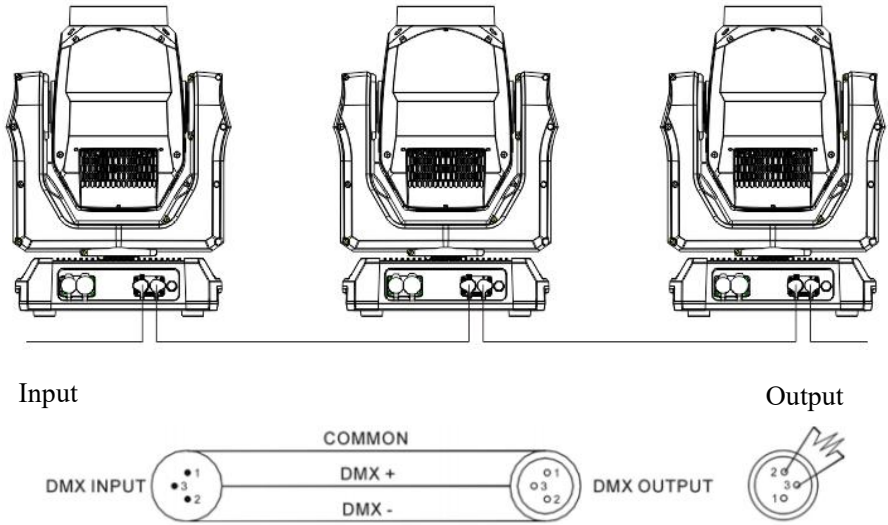

### 6.4 Alignment/ Installation/Replacement of a lamp

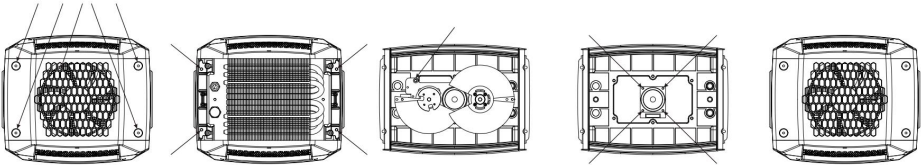

**Figure 1:** First, loosen the four screws securing the lamp head rear plastic housing, remove the housing, then loosen the fan screws and set the fan aside.

**Figure 2:** Next, loosen the three screws on the bulb rear cover plate, then loosen the remaining screw and set all components aside.

**Figure 3:** Loosen the four screws on the bulb pressure plate, lift the pressure plate away, take out the bulb, disconnect the bulb power cable, then remove the bulb for replacement.

**Figure 4:** After installing the new bulb, first reconnect the bulb power cable and ensure the bulb is securely clamped. Then power on the lamp and adjust the bulb so its center is aligned to the middle position. Once adjusted, reinstall the bulb rear cover plate, fan, and lamp head rear plastic housing.

## **Operational Safety Precautions**

1. **Power-off Operation:** The main power supply of the equipment must be cut off before operation to avoid the risk of electric shock.
2. **Anti-scalding Treatment:** If the equipment has just been used, wait for the lamp body and bulb to cool down before operation to prevent scalding from high temperatures.
3. **Handle with Care:** The bulb is a fragile item; avoid collision and extrusion when taking and placing it. When disassembling and assembling the radiator module, operate steadily to prevent damage to parts.
4. **Wiring Specification:** Align the connectors when plugging in the wires; avoid forced plugging and unplugging, which may cause poor contact or damage to the circuit.

## **7. Maintenance & Cleaning**

Regular maintenance is essential to ensure optimal performance and extend the service life of the fixture.

### **7.1 Cleaning**

Disconnect the unit from power before any cleaning work.

Use a soft, lint-free cloth slightly dampened with mild detergent to clean the exterior surfaces.

Gently remove dust from ventilation slots, optical lenses, and cooling components using compressed air or a soft brush.

Avoid using solvents, alcohol, or abrasive materials that may damage the housing or optical elements.

### **7.2 Lubrication**

This fixture is designed with sealed or maintenance-free moving parts. Under normal operating conditions, no additional lubrication is required.

If abnormal noise or movement resistance is observed, contact qualified service personnel before applying any lubricant.

### **7.3 Troubleshooting**

If the fixture does not power on, verify the power supply, cables, and connectors.

For control issues, check DMX addressing, cable integrity, and ensure proper 3-pin XLR connections.

Overheating or unexpected shutdown may indicate blocked ventilation; inspect and clean air inlets and outlets.

If problems persist after basic checks, discontinue use and contact authorized service technicians.



**LEAHUA**

Guangzhou Leahua Lighting Technology Ltd

---

---

Rm 1004, Building A  
Baiyun Lake Future Technology Center  
No.1 Xinghu Street, Shimen, Baiyun district  
Guangzhou 510440, China

---

---